

EP

ELETTROPOMPE IN BRONZO BRONZE ELECTRIC PUMPS

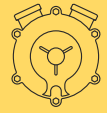

EP 70

EPH 20-25 MF
EP 20-25-30-40-50 MF/TF



EP 20-25-30-40-50 CC

I		MF	2m + SCHUKO
		TF	4m
L			IP55 2m + SCHUKO
M		Morsettiera Terminal board connection	IP55

ELETTROPOMPE MONOFASE (MF) O TRIFASE (TF) - 50 Hz / SINGLE-PHASE (MF) OR THREE PHASE (TF) ELECTRIC PUMPS - 50 Hz

Modello Type	Maniglia Handle	Motore Motor	Volt	Hz	kW	Giri/min. RPM	H = Prevalenza (metri) / Head (meters) - Q = Portata (l/min.) / Capacity (l/min.)														
							0	5	10	12	15	18	22	24	30	35	40	H			
EPH 20	●	L MF	230	50	0.22	2800	29	20	10	6	0										
EPH 25	●	L MF	230	50	0.45	2800	60	47	30	23	12	0									
EP 20	●	M MF	230	50	0.22	2800	29	20	10	6	0										
	●	M MF	110	50	0.22	2800	29	20	10	6	0										
	●	I TF	230-400	50	0.26	2800	29	20	10	6	0										
EP 25	●	M TF	230-400	50	0.26	2800	29	20	10	6	0										
	X	M MF	230	50	0.45	2800	60	47	30	23	12	0									
	X	M MF	110	50	0.45	2800	60	47	30	23	12	0									
EP 30	X	I TF	230-400	50	0.56	2800	60	47	30	23	12	0									
	X	M TF	230-400	50	0.56	2800	60	47	30	23	12	0									
	X	M MF	230	50	0.75	1400	75	60	40	30	15	0									
EP 40	X	M MF	110	50	0.75	1400	75	60	40	30	15	0									
	X	I TF	230-400	50	0.75	1400	75	60	40	30	15	0									
	X	M TF	230-400	50	0.75	1400	75	60	40	30	15	0									
EP 50	X	I MF	230	50	0.75	1400	120	105	85	80	62	45	0								
	X	I MF	110	50	0.75	1400	120	105	85	80	62	45	0								
	X	I MF	230	50	1.1	1400	120	105	85	80	62	45	0								
	X	I MF	110	50	1.1	1400	120	105	85	80	62	45	0								
	X	I TF	230-400	50	0.75	1400	120	105	85	80	62	45	0								
	X	I TF	230-400	50	1.1	1400	120	105	85	80	62	45	0								
	X	M TF	230-400	50	1.1	1400	120	105	85	80	62	45	0								
EP 70	n.d.	I MF	230	50	1.87	1400	230	205	175	160	140	120	80	60	0						
	n.d.	I MF	110	50	1.87	1400	230	205	175	160	140	120	80	60	0						
	n.d.	I TF	230-400	50	1.87	1400	230	205	175	160	140	120	80	60	0						
	n.d.	M TF	230-400	50	1.87	1400	230	205	175	160	140	120	80	60	0						
EP 70	n.d.	M TF	230-400	50	5.5	1400	500	455	415	390	365	330	280	255	165	90	0				
	n.d.	M TF	230-400	50	7.5	1400	500	455	415	390	365	330	280	255	165	90	0				

ELETTROPOMPE A CORRENTE CONTINUA (CC) CON MANIGLIA/ DIRECT CURRENT ELECTRIC PUMPS (CC) WITH HANDLE

Modello Type	Maniglia Handle	Motore Motor	Volt	A	kW	Giri/min. RPM	H = Prevalenza (metri) / Head (meters) - Q = Portata (l/min.) / Capacity (l/min.)														
							0	5	8	10	12	15	18	20	22	24	30	H			
EP 20	●	M CC	12	26	0.33	2000	25	15	6	0											
	●	M CC	24	14	0.33	2000	25	15	6	0											
EP 20 T	●	M CC	12	36	0.45	3000	32	26	22	19	16	12	7	3	0						
	●	M CC	24	22	0.45	3000	32	26	22	19	16	12	7	3	0						
EP 25	●	M CC	12	38	0.45	2000	53	35	22	12	0										
	●	M CC	24	22	0.45	2000	53	35	22	12	0										
EP 30	●	M CC	24	28	0.6	1400	75	60	47	40	30	15	0								
EP 40	●	M CC	24	45	1.1	1400	120	105	95	85	80	62	45	30	0						
EP 50	n.d.	M CC	24	95	1.5	1400	230	205	185	175	160	140	120	95	80	60	0				

● = Pompe con maniglia inclusa / Pumps with handle included - X = disponibile a richiesta / available on request - n.d. = non disponibile / not available

ELETTROPOMPE MONOFASE (MF) O TRIFASE (TF) - 60 Hz / SINGLE-PHASE (MF) OR THREE PHASE (TF) ELECTRIC PUMPS - 60 Hz

Modello Type	Maniglia Handle	Motore Motor	Volt	Hz	kW	Giri/min. RPM	H = Prevalenza (metri) / Head (meters) - Q = Portata (l/min.) / Capacity (l/min.)														
							0	5	10	15	18	22	24	30	35	40	45	H			
EP 20	●	M MF	230	60	0.26	3300	35	31	25	16	10	3	0								
	●	M MF	110	60	0.26	3300	35	31	25	16	10	3	0								
	●	I TF	230-400*	60	0.31	3300	35	31	25	16	10	3	0								
	●	M TF	230-400*	60	0.31	3300	35	31	25	16	10	3	0								
EP 25	X	M MF	230	60	0.54	3300	75	63	50	34	24	8	0								
	X	M MF	110	60	0.54	3300	75	63	50	34	24	8	0								
	X	I TF	230-400*	60	0.67	3300	75	63	50	34	24	8	0								
	X	M TF	230-400*	60	0.67	3300	75	63	50	34	24	8	0								
EP 30	X	M MF	230	60	0.90	1700	95	78	60	37	23	0									
	X	M MF	110	60	0.90	1700	95	78	60	37	23	0									
	X	I TF	230-400*	60	0.90	1700	95	78	60	37	23	0									
	X	M TF	230-400*	60	0.90	1700	95	78	60	37	23	0									
EP 40	X	I MF	230	60	1.34	1700	150	130	107	80	60	25	0								
	X	I MF	110	60	1.34	1700	150	130	107	80	60	25	0								
	X	I TF	230-400*	60	1.34	1700	150	130	107	80	60	25	0								
	X	M TF	230-400*	60	1.34	1700	150	130	107	80	60	25	0								
EP 50	n.d.	I MF	230	60	2.23	1700	250	225	200	165	145	115	100	45	0						
	n.d.	I MF	110	60	2.23	1700	250	225	200	165	145	115	100	45	0						
	n.d.	I TF	230-400*	60	2.60	1700	250	225	200	165	145	115	100	45	0						
	n.d.	M TF	230-400*	60	2.60	1700	250	225	200	165	145	115	100	45	0						
EP 70	n.d.	M TF	230-400*	60	9.00	1700	570	530	490	440	400	360	340	260	190	100	0				

● = Pompe con maniglia inclusa / Pumps with handle included - X = disponibile a richiesta / available on request - n.d. = non disponibile / not available
 * A richiesta disponibile anche 255-440V e 277-480V / Available on request 255-440V and 277-480V

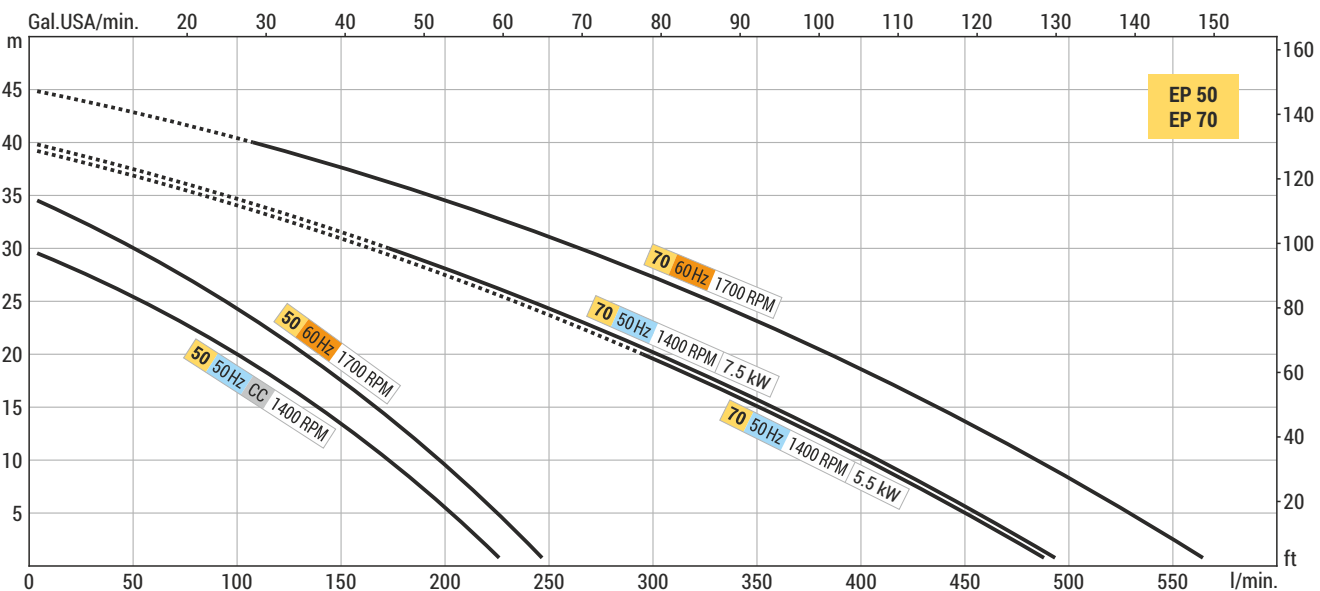
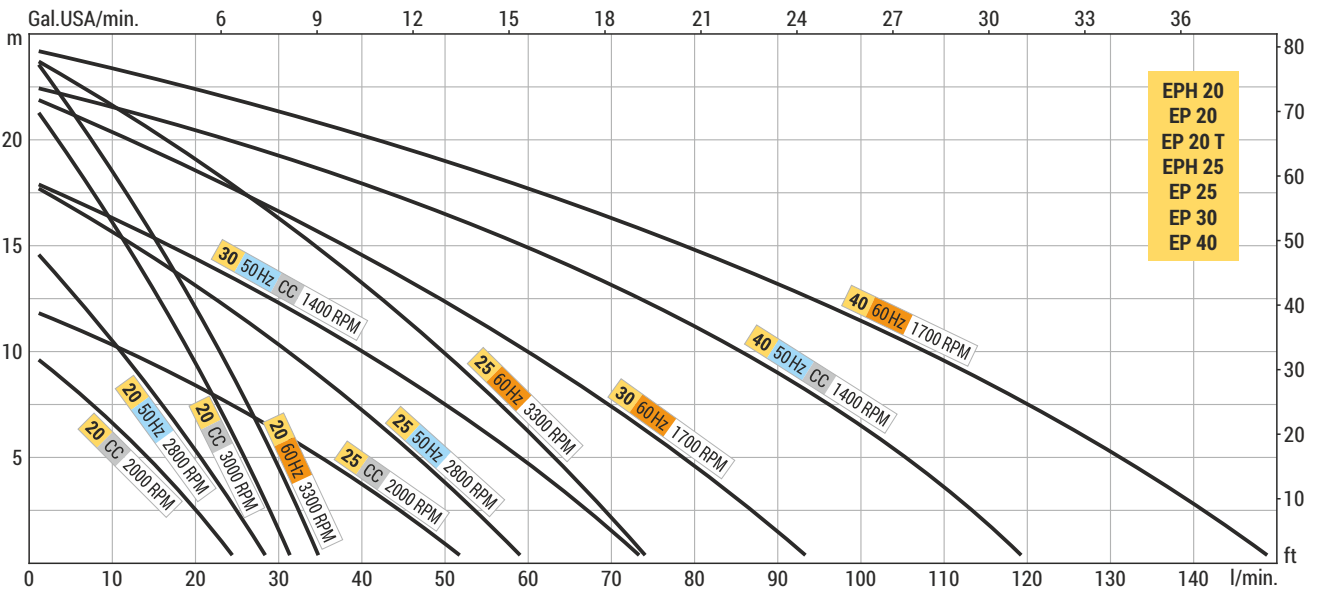

EPH 20
EP 20

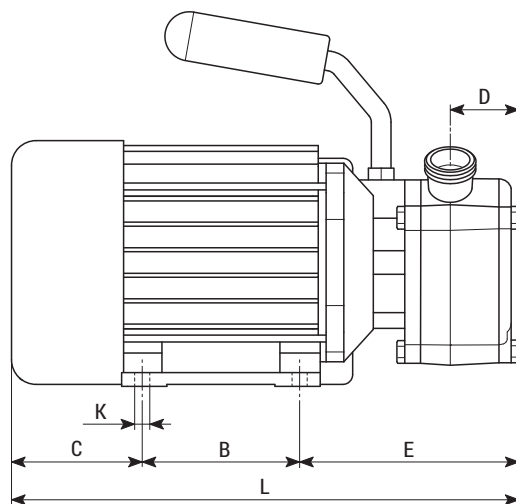
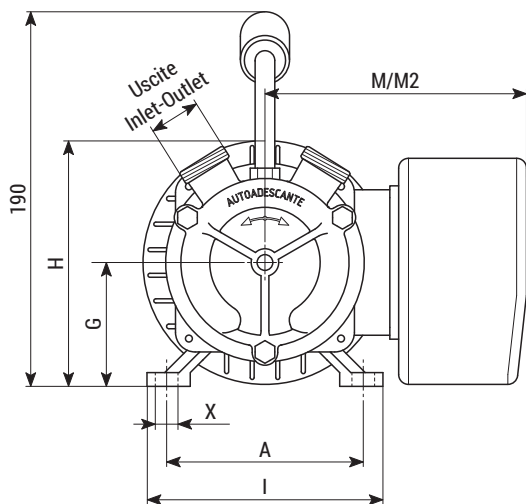

EPH 25
EP 25

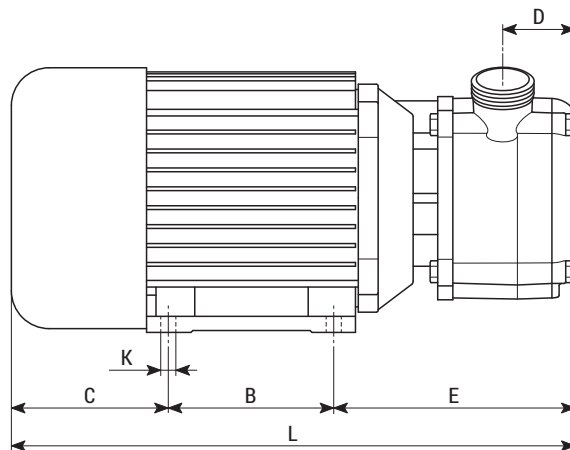
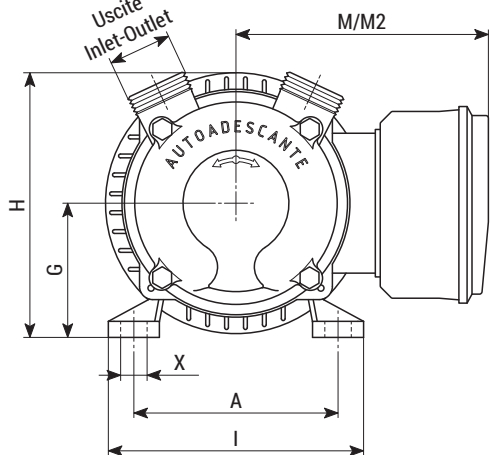

EP 20 CC
EP 20 T
EP 25 CC

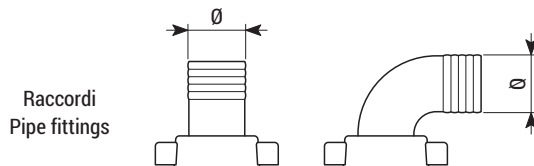
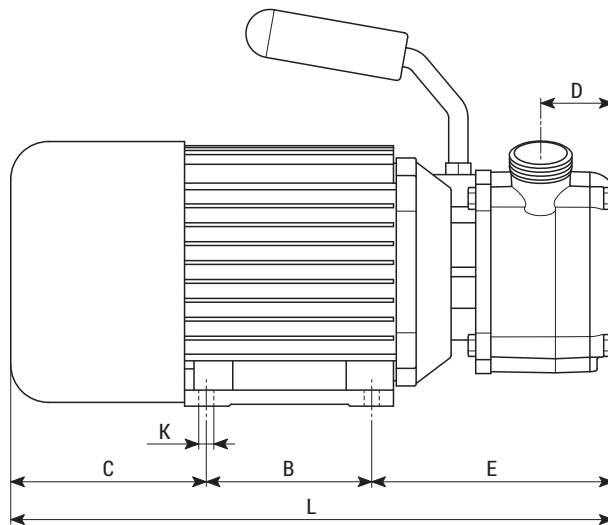
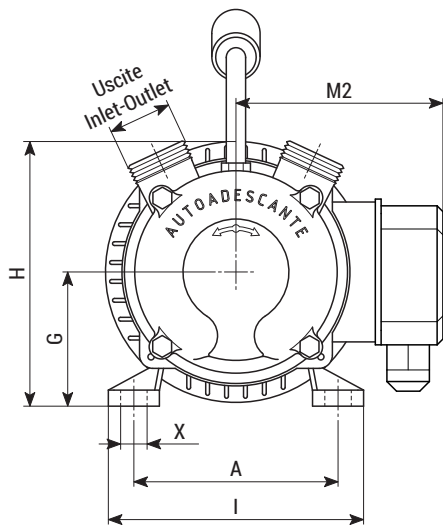

Tipo Type	Uscite Inlet-Outlet	Raccordi Pipe fittings	Motore Motor	Peso Weight	Dimensioni (mm) / Dimensions (mm)														
					A	B	C	D	E	G	H	I	K	L	M*	M2*	N	X	
EPH 20	BSP-M 3/4"	Ø20	MF	5.5 kg	90	80	70	35	110	63	100	110	7	260	115	-	-	10	
EPH 25	BSP-M 1"	Ø25	MF	9.2 kg	112	90	78	40	127	71	124	136	7	295	125	-	-	12	
EP 20	BSP-M 3/4"	Ø20	CC	5.7 kg	100	80	100	35	115	63	106	120	7	295	-	100	-	12	
			MF/TF	5.6 kg	90	80	70	35	110	63	100	110	7	260	135	105	-	10	
EP 25	BSP-M 1"	Ø25	CC	9.3 kg	112	80	108	40	133	71	124	132	8	320	-	110	-	12	
			MF/TF	9.2 kg	112	90	88	40	127	71	124	136	8	305	145	110	-	12	

n.d. = Raccordi non disponibili / Pipe fittings not available

M* = interruttore/invertitore-portacondensatore / on-off reverse switch-capacitor box - M2* = morsettiera / terminal board connection

EP 30
EP 40
EP 50

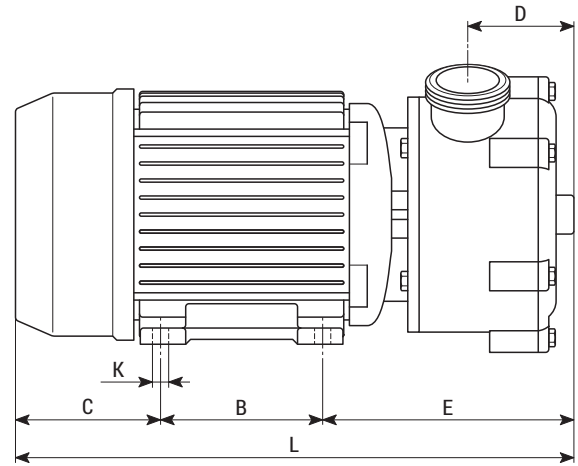
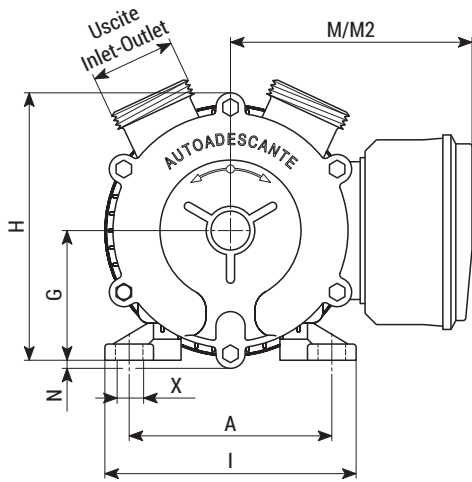

EP 70

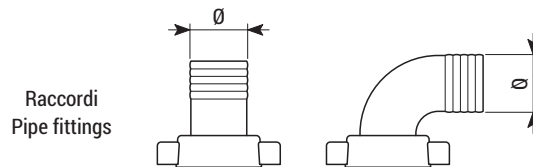
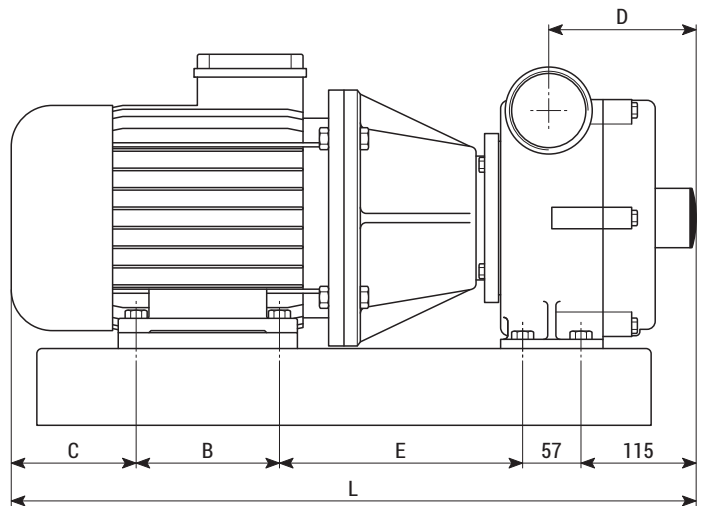
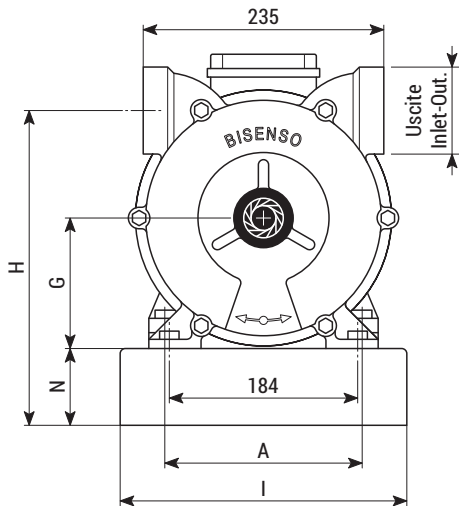

Tipo Type	Uscite Inlet-Outlet	Raccordi Pipe fittings	Motore Motor	Peso Weight	Dimensioni (mm) / Dimensions (mm)													
					A	B	C	D	E	G	H	I	K	L	M*	M2*	N	X
EP 30	BSP-M 1"1/4	Ø30	CC	13.2 kg	125	100	135	50	140	80	165	160	8	375	-	125	5	16
			MF/TF	12.7 kg	125	100	90	50	140	80	165	155	10	330	155	125	5	17.5
EP 40	BSP-M 1"1/2	Ø40	CC	20.0 kg	140	125	185	67	180	90	175	175	10	490	-	130	-	17.5
			MF/TF	14.5 kg	125	100	90	67	162	80	165	155	10	352	155	125	5	17.5
EP 50	BSP-M 2"	Ø50	CC	31.9 kg	140	125	137	90	180	90	194	175	10	442	-	-	14	17.5
			MF/TF	26.5 kg	140	125	100	90	210	90	194	175	10	435	160	130	14	17.5
EP 70	BSP-F 2"1/2	n.d.	TF 5.5 kW	76.5 kg	200	140	137	146	242	128	306	270	11	690	-	-	72.5	18
			TF 7.5 kW	90.0 kg	216	178	155	144	280	156	334	280	11	785	-	-	72.5	18

n.d. = Raccordi non disponibili / Pipe fittings not available

M* = interruttore/invertitore-portacondensatore / on-off reverse switch-capacitor box - M2* = morsettiera / terminal board connection